

Vision

Stockmanship is handling cattle with the intent of enhancing profitability through the following avenues:

- Improve consumer confidence that cattlemen are good stewards of livestock
- By working with the natural instincts of cattle during handling, safety of animals and handlers can be improved
- Low-stress handling techniques enhance animal health and assure a higher response to medicines

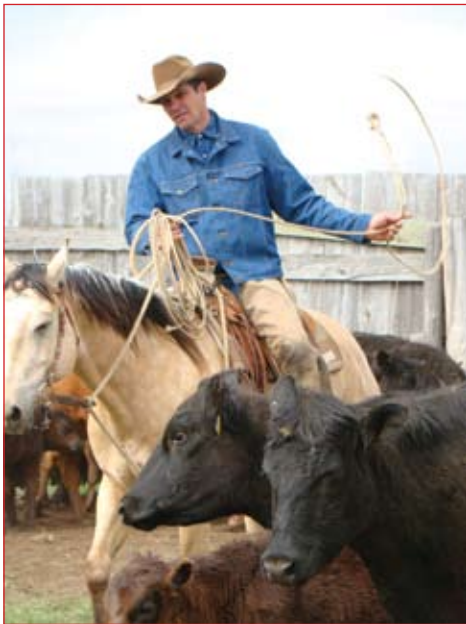

Topics

- Gathering cattle from pasture
- Working cattle in corrals and alleyways
- Sorting and processing techniques
- Strategies for receiving cattle
- Low-stress loading procedures
- Proper use of equipment to assure low-stress handling

Sponsors



Land O'Lakes Purina Feed



Midcontinent Livestock Supplements



The "FUTURE" in Livestock Nutrition "NOW"



World leaders in weighing



Endorsed by:



STOCKMANSHIP AND STEWARDSHIP

Creating and managing movement is the key to effective cattle handling



Funded by The Beef Checkoff

A SAFE, WHOLESOME AND HEALTHY BEEF SUPPLY

## Why This is Important To You and the Beef Cattle Industry

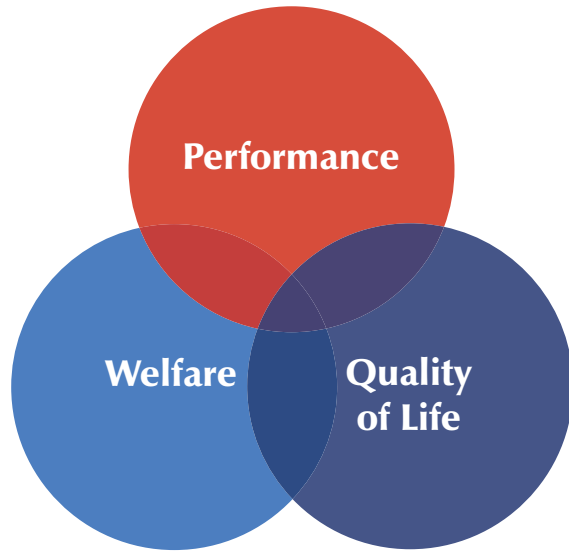

### Welfare

- Improved cattle handling leads to improved public perception
- Less injury to handlers and cattle
- Less carcass damage and trim loss

### Performance

- Increase efficiency
- Increased gain
- Less investment in veterinary intervention
- Less investment into facilities and repair

### Quality of Life

- Improved profitability
- Sustainable family operations
- Enjoyment of the ranching lifestyle

## The “Bud Box” Concept for Cattle Pens

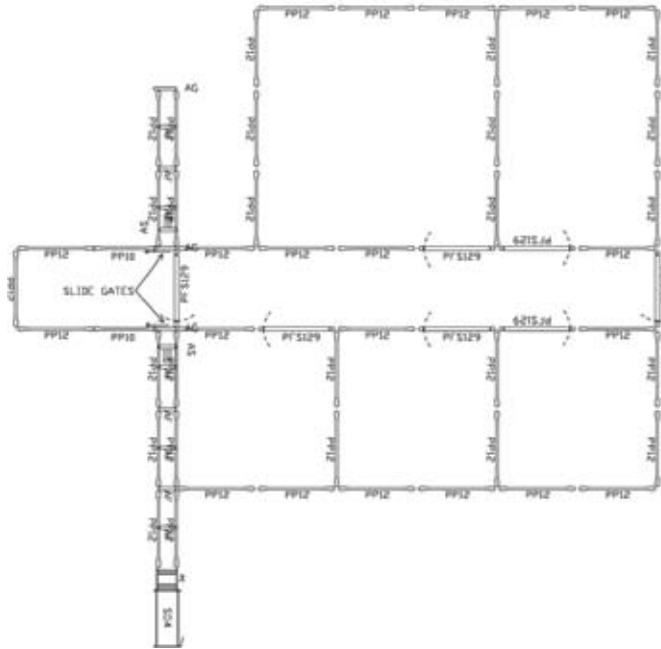

## Priefert 90 Degree Sweep System

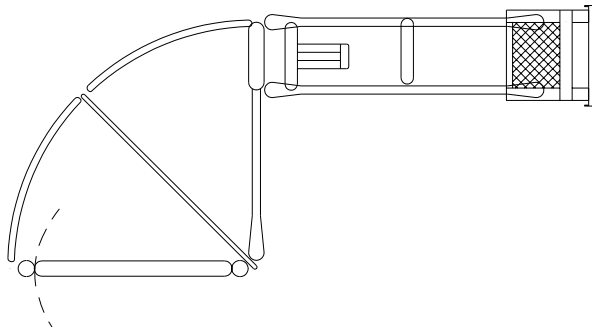

## Curt Pate

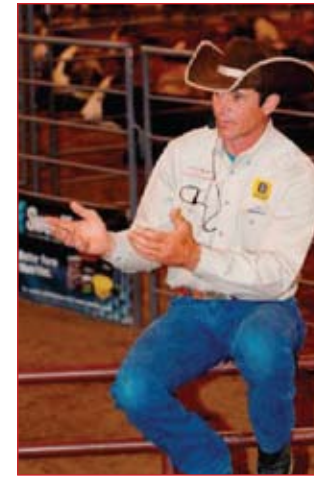

For more than a decade Curt has conducted demonstrations and clinics on stockmanship, colt starting, horsemanship and safety. His abilities conducting both horsemanship and stockmanship demonstrations along with his ability as an effective communicator make him one of the most sought after clinicians on both the national and international scene.

His personal experience incorporating effective stockmanship principles supports a “for profit” mindset; he fully understands the increased economic benefits of handling stock correctly. Just as important, as livestock production comes under increased scrutiny, is the understanding Curt has of the impact that improved handling practices create for the sustainability of the cattle industry.

Curt brings great value to the livestock industry. In addition to devoting his time conducting stockmanship presentations, he manages his own ranch operation in Montana. With his ability to think outside the box, his ability to challenge others to do the same, and a willingness to share his skills, Curt has set himself apart in conducting stockmanship clinics. His lifelong experience in ranching adds credibility and enables him to communicate his methods effectively to cattle ranchers throughout the country.

Recognized for his horsemanship skills, Curt has been selected by the American Quarter Horse Association to serve as an AQHA Professional Horseman as well as their Regional Experience Clinician.

## Contact NCBA to schedule

Call or e-mail either  
 Tom Field at 303.850.3378 • tfield@beef.org or  
 Grace Webb at 303.850.3338 • gwebb@beef.org